



Enriching Lives

## Canned Motor Pump - i-CM



**KIRLOSKAR BROTHERS LIMITED**

Established 1888

A Kirloskar Group Company

## CUT-SECTIONAL VIEW

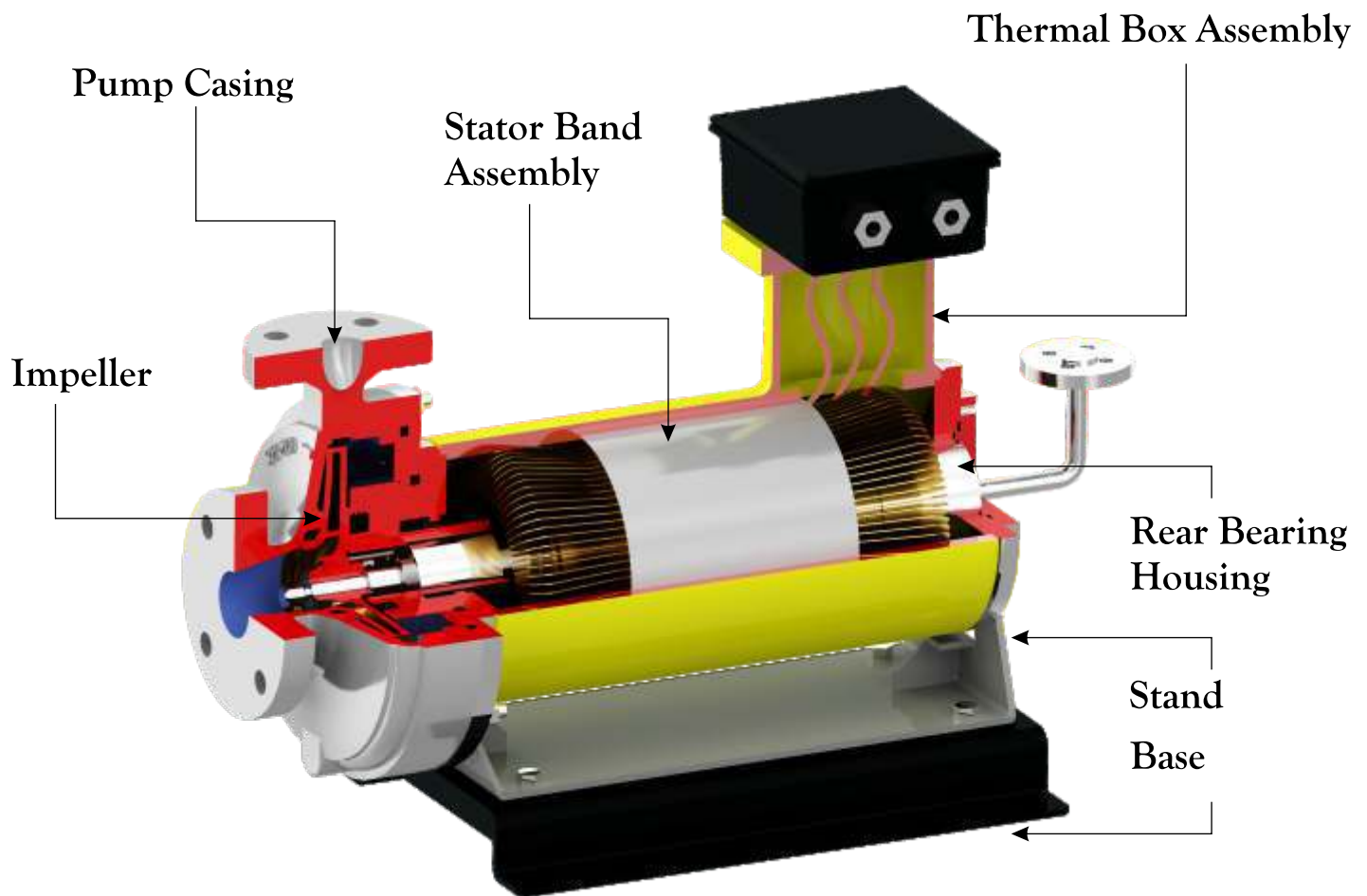

### RANGE

Delivery size	:	32 to 50 mm
Capacity	:	4 to 80 m <sup>3</sup> /hr
Head	:	up to 60 meters
Speed	:	2900 rpm
Temperature	:	Up to 90°C (standard)
Rating	:	3.7kW to 7.5kW

### APPLICATIONS

- Refrigeration (cold storage)
- Ice plants
- Chemical and Process industries
- Windmills

i-CM pumps are mainly used for pumping hazardous fluid such as radioactive coolant, corrosive and noxious liquid (free of suspended solids and particles), liquefied gases, etc.

## CONSTRUCTIONAL FEATURES

### Casing:

The casing has axial suction and top center line delivery with self-venting design. Smooth hydraulic passage ensures high efficiency. Delivery flanges and supporting feet are cast integral with the casing.

### Impeller:

The impeller is of enclosed type. Hydraulic balancing of impeller is achieved by balance holes depending upon magnitude of axial thrust. The impeller is statically and dynamically balanced.

### Shaft:

The shaft is supported between Carbon Graphite bush bearings. The critical speed of shaft is sufficiently above the operating speed. The shaft is critically machined and ground to maintain concentricity. There is common shaft for pump and motor.

### Wear Rings:

Replaceable wear rings are provided on Casing and Impeller.

### Bearings:

The Carbon Graphite Bush Bearings are used to support the whole assembly. Bearing lubrication is done with the help of same liquid which is to be pumped

### Thrust Washer:

Thrust Washers are provided to absorbing axial thrust.

### Direction of Rotation:

Direction of rotation is Anti-Clockwise when viewed from suction end.

### Motor:

Motor is mounted on same shaft of pump. Type of starting for motor is Direct On Line (DOL). Motor class of Insulation will be "F". Motor is with 415V/3 Ph / 50 Hz supply. RTD's or thermostats connections are provided in each phase of motor to monitor winding temperature continuously.

### Constructional Features:

- Seal less and glandless design
- Eco friendly
- Integral Motor design
- Ease installation
- Less space required for foundation
- Compact in construction and light in weight
- Integral Adaptor Plate
- Less no of parts
- Integral Rear Cover and Rear Bearing Housing
- Good Aesthetic design
- Stator Band can be manufactured with the help of seamless pipe
- Quiet in operation
- Centerline delivery self-venting
- Back pullout type design
- Flange drilling : ANSI class, 300 FF
- Auxiliary tapping : NPT
- Performance testing standard : IS09906 Gr.2B
- Interchangeability of components
- Special alignment is not required due to mono-block construction
- No external lubrication is required for bearings.
- Motor is protected from liquid with the help of Can provided on the Stator ID and Rotor OD.

**EXPLODED VIEW**

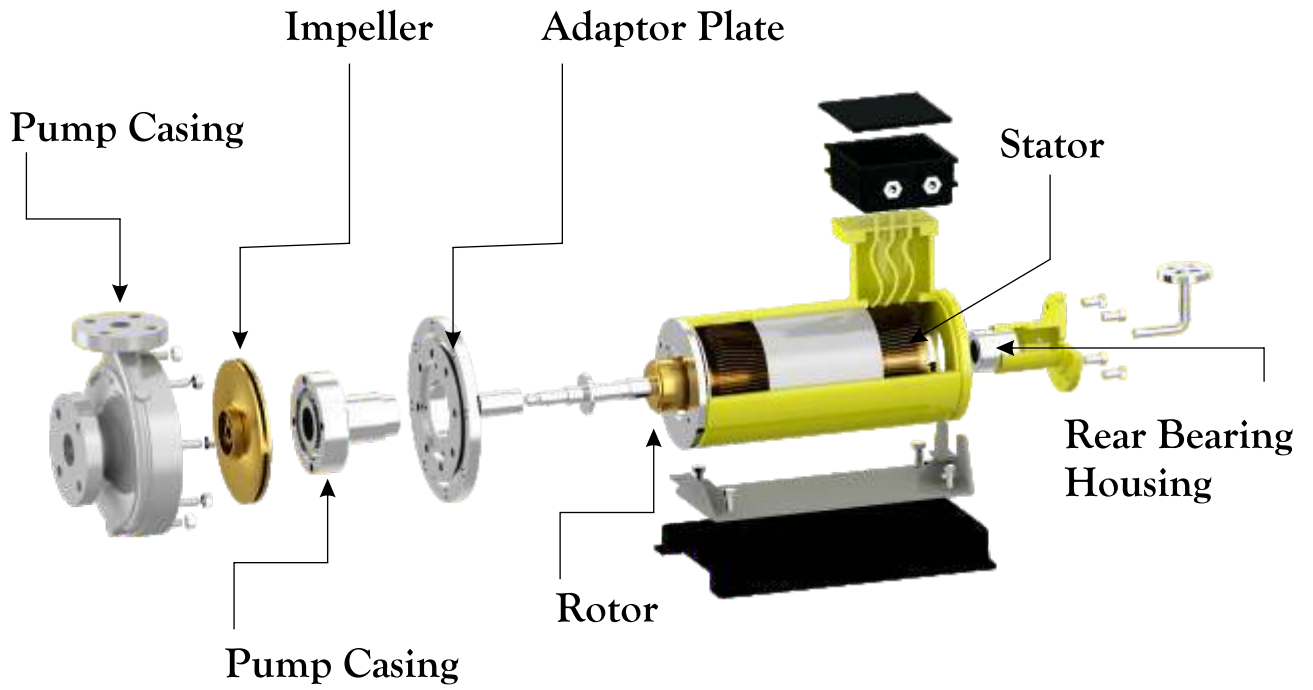

**GENERAL DIMENSIONS & MOUNTING DETAILS**

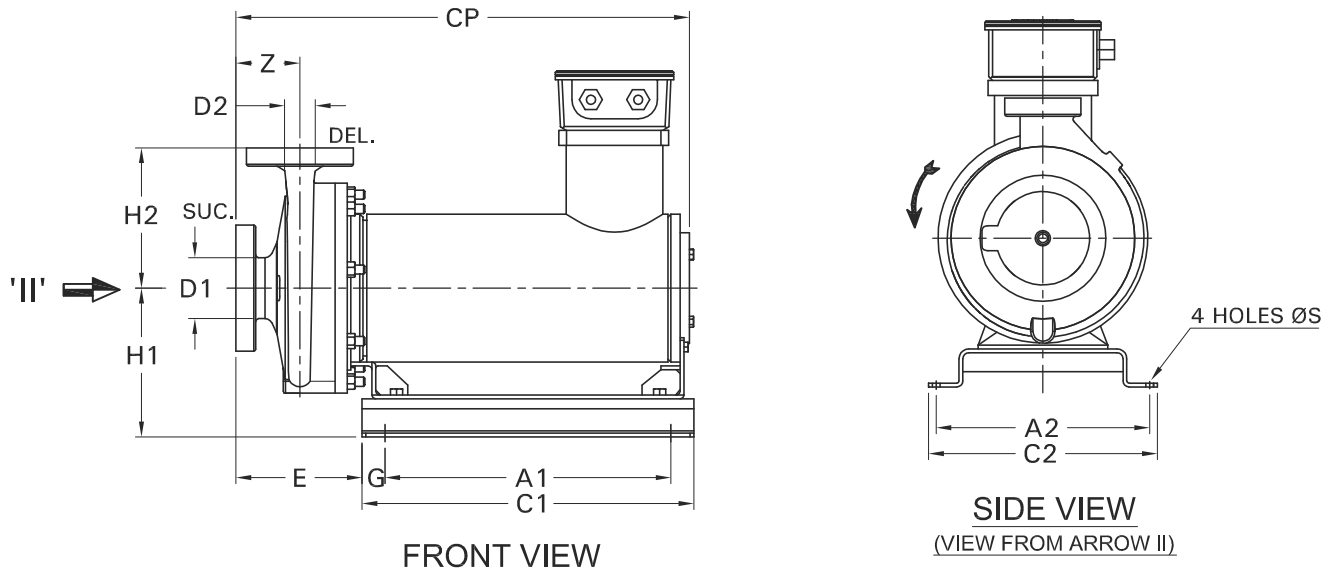

S.No.	Pump Model	A1	A2	C1	C2	D1	D2	E	H1	H2	Z	G	CP	S
1	I-CM32/16- 3.7KW/2P	335	270	435	300	50	32	160	195	160	80	50	585	11.5
2	i-CM32/16- 5.5KW/2P	335	270	435	300	50	32	160	195	160	80	50	585	11.5
3	I-CM32/20- 3.7KW/2P	335	270	435	300	50	32	160	195	180	80	50	585	11.5
4	i-CM32/20- 5.5KW/2P	335	270	435	300	50	32	160	195	180	80	50	585	11.5
5	I-CM32/20- 7.5KW/2P	380	270	480	300	50	32	160	195	180	80	50	630	11.5
6	i-CM40/13- 3.7KW/2P	335	270	435	300	65	40	160	195	140	80	50	585	11.5
7	i-CM40/16- 3.7KW/2P	335	270	435	300	65	40	160	195	160	80	50	585	11.5
8	i-CM40/16- 5.5KW/2P	335	270	435	300	65	40	160	195	160	80	50	585	11.5
9	i-CM50/13- 3.7KW/2P	335	270	435	300	80	50	180	195	160	100	50	605	11.5
10	i-CM50/13- 5.5KW/2P	335	270	435	300	80	50	180	195	160	100	50	605	11.5
11	i-CM50/13- 7.5KW/2P	380	270	480	300	80	50	180	195	160	100	50	650	11.5
12	I-CM40/20- 5.5KW/2P	335	270	435	300	65	40	180	195	180	100	50	605	11.5

## CROSS-SECTIONAL ASSEMBLY

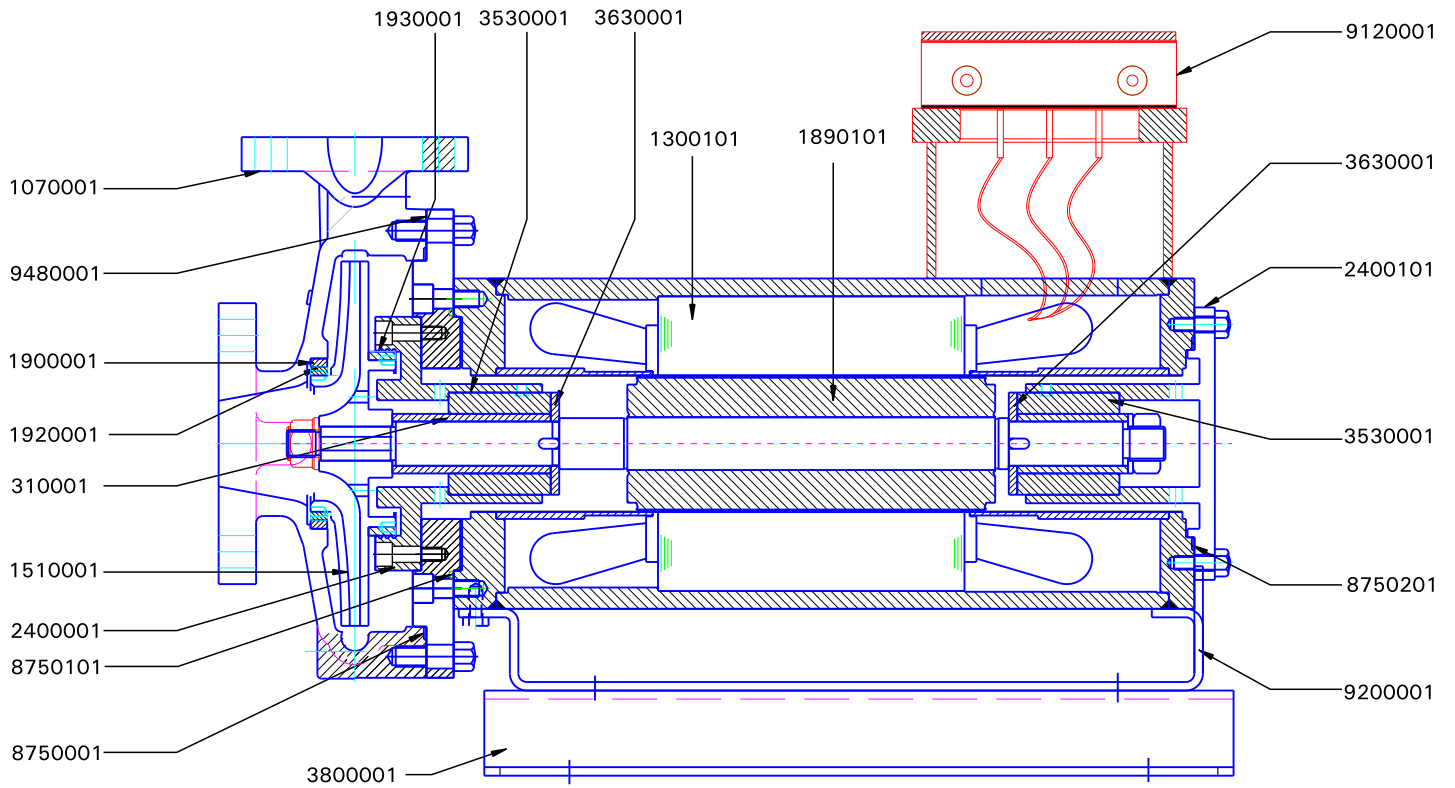

ITEM	PART NAME
1070001	CASING
1510001	IMPELLER
1300101	STATOR
1890101	ROTOR
9480001	LINER DISC
2400001	FRONT BEARING HSG.
2400101	REAR BEARING HSG.
3100101	SLEEVE UNDER BEARING
3530001	BEARING BUSH
3630001	THRUST WASHER
1940101	TERMINAL COVER
9120001	TERMINAL BOX ASSEMBLY
9200001	STAND
3800001	BASE
8750001	GASKET FOR LINER DISC & CASING.
8750101	"O"RING FOR LINER DISC & STATOR BAND
8750201	GASKET FOR REAR BRG HOUSING & STATOR BAND
6180201	STATOR LINER
3110001	ROTOR LINER

## MATERIALS

### MATERIAL OF CONSTRUCTION

• Pump Casing / Adaptor Plate	: SG Iron / SS CF8M/ WCB
• Impeller	: Cast Iron / Bronze / CF8M/ Cf8/ WCB
• Wear Rings	: Cast Iron / Bronze/ CF8M/CF8/ CA15H/ SS410H
• Pump Shaft	: SS410 / SS316L
• Shaft Sleeve	: St. Steel –ASTMA 276 Type 316CP /410H
• Stator / Rotor Can	: SS316 / SS316L
• Bush Bearings	: Carbon Graphite / Silicon Carbide
• Thrust Washer	: SS410 with Chrome Plating

### MATERIAL STANDARDS - GENERAL INFORMATION

Material Type	Indian Standard (IS)	American standard (ASTM)	DIN
<b>Cast Iron</b>			
Cast Iron	IS 210 Gr. FG 260	ASTM A48 Class 40	(0.6025)DIN 1691 GG25
<b>Spheroidal Graphite Cast Iron</b>			
SG Iron (Ductile Iron)	IS 1865 Gr 400/15	A536, 60-40-18	(0.7040)DIN1693 GGG40
SG Iron (Ductile Iron)	IS 1865 Gr 500/7	A536, 65-45-12	(0.7050)DIN1693 GGG50
<b>Carbon steel</b>			
Carbon steel (Wrought)	IS 1570 (part II) Gr. 40C8	ASTM A107 Gr. 1040	(1.1186)C40E/CK40
Carbon steel (Wrought)	IS 1570 (part II) Gr. 20C8	ASTM A107 Gr. 1020	(1.0402)C22
MS Steel	MS IS 2062 - Fe 410 W A	ASTM-A283 GR.D	DIN 1700 GR ST4-2 FABRICATED STEEL44
<b>Cast Steel Grades</b>			
Cast steel		ASTMA 216 Gr. WCB	1.0619(GS-C25)
<b>Cast Stainless Steel</b>			
Stainless Steel CF8M	IS 3444 Gr. 4	ASTMA 351 Gr. CF8M	1.4408(GX5CrNiMo19-11-2)
Stainless Steel CF8M	IS 3444 Gr. 4	ASTMA 743 Gr. CF8M	1.4408(GX5CrNiMo19-11-2)
Stainless Steel CF3M	IS 3444 Gr. 16	ASTMA 351 Gr. CF3M	1.4409(GX2CrNiMo19-11-2)
Stainless Steel CF3M	IS 3444 Gr. 16	ASTMA 743 Gr. CF3M	1.4409(GX2CrNiMo19-11-2)
Stainless Steel CF8	IS 3444 Gr. 1	ASTMA 351 Gr. CF8	1.4301(X5CrNi18-10)
Stainless Steel CF3	IS 3444 Gr. 15	ASTMA 351 Gr. CF3	1.4306(X2CrNi19 11)
<b>Cast Chromium StainlessSteel</b>			
Stainless Steel CA15	IS 3444 Gr. 10	ASTMA 217 Gr. CA15	1.4106&1.448(DIN17445 GX12Cr14)
Stainless Steel CA15	IS 3444 Gr. 10	ASTMA 743 Gr. CA15	1.4106&1.448(DIN17445 GX12Cr14)
Stainless Steel CA6NM	IS 3444 Gr. 24	ASTMA 487 Gr. CA6NM	1.4313&1.4317(GX5CrNiMo13-4)
Stainless Steel CA6NM	IS 3444 Gr. 24	ASTMA 743 Gr. CA6NM	1.4313&1.4317(GX5CrNiMo13-4)
<b>Chromium StainlessSteel Round Bar Material</b>			
Stainless steel 410	IS 1570 (part V) Gr. X12Cr12	ASTMA 276 type 410	1.4006(X10Cr13)
Stainless steel 420	IS 1570 (part V) Gr. X20Cr13	ASTMA 276 type 420	1.4021(X20Cr13)
Stainless steel 431	IS 1570 (part V) Gr. X15Cr16Ni2	ASTMA 276 type 431	1.4057(X20CrNi17)
Stainless steel 316	IS 1570 (part V) Gr. X04Cr17Ni12Mo2	ASTMA 276 type 316	1.4401(X5CrNiMo17122)
Stainless steel 316L	IS 1570 (part V) Gr. X02Cr17Ni12Mo2	ASTMA 276 type316L	1.4404(X2CrNiMo1810)
<b>Cast Duplex Steel</b>			
Duplex Steel 1A		ASTMA 890 Gr. CD4MCu	25Cr-5Ni-Mo-Cu
Duplex Steel 2A		ASTMA 890 Gr. CE8MN	24Cr-10Ni-Mo-N
Duplex Steel 3A		ASTMA 890 Gr. CD6MN	25Cr-5Ni-Mo-N
Super Duplex steel 4A		ASTMA 890 Gr. CD3MN	25Cr-7Ni-Mo-N
Super Duplex steel 5A		ASTMA 890 Gr. CE3MN	24Cr-10Ni-Mo-N
<b>Non Ferious Materials</b>			
Bronze	IS 318 Gr. LTB2 (CuSn5Zn5Pb5C)	ASTMB 584 - C90500	DIN 1705 Rg 5
Phosphor Bronze	IS 28 Gr. 1 (CuSn11PC)		
Zinc Free Bornze	IS 28 Gr. 1 (CuSn10C)		

## Value Added Features

KBL offers multiple “value added features” including advance monitoring systems with pump controller (temperature indication, discharge/suction pressure indication, vibration and dry run indication), alternative material for impeller and pump casing and alternative bearing material that ensures long life of the pump.

## FAMILY CURVES

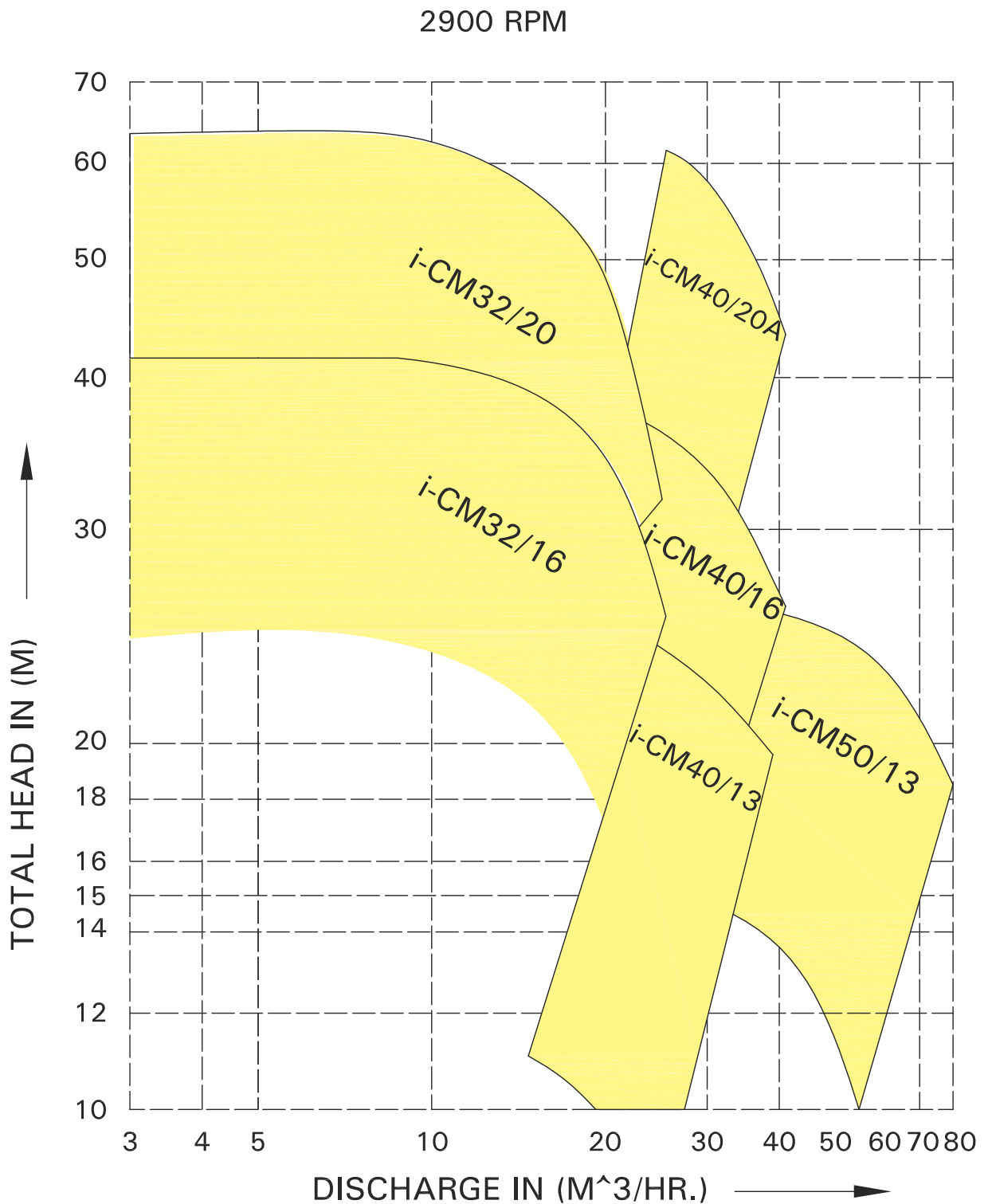

# ABOUT KBL

Kirloskar Brothers Limited (KBL) is a world class pump manufacturing company with expertise in engineering and manufacture of systems for fluid management. Established in 1888 and incorporated in 1920, KBL is the flagship company of the \$ 2.1 billion Kirloskar Group. KBL, a market leader, provides complete fluid management solutions for large infrastructure projects in the areas of water supply, power plants, irrigation, oil & gas and marine & defence. We engineer and manufacture industrial, agriculture and domestic pumps, valves and hydro turbines.

In 2003, KBL acquired SPP Pumps, United Kingdom and established SPP INC, Atlanta, USA, as a wholly owned subsidiary of SPP, UK to expand its international presence. In 2007, Kirloskar Brothers International B.V., The Netherlands and Kirloskar Brothers (Thailand) Ltd., a wholly owned subsidiary in Thailand, were incorporated. In 2008, KBL incorporated Kirloskar Brothers Europe B.V. (Kirloskar Pompen B.V. since June 2014), a joint venture between Kirloskar International B.V. and Industrial Pump Group, The Netherlands. In 2010, KBL further consolidated its global position by acquiring Braybar Pumps, South Africa. SPP MENA was established in Egypt in 2012. In 2014, KBL acquired SyncroFlo Inc., the largest independent fabricator of commercial and municipal domestic water booster pumps.

To further strengthen its global position, in 2015, Kirloskar Pompen B.V. acquired Rodelta Pumps International, The Netherlands.

KBL has joint venture cooperation with Ebara, Japan since 1988 for the manufacture of API 610 standard pumps. Kirloskar Corrocoat Private Limited is a joint venture cooperation with Corrocoat, UK since 2006. KBL acquired The Kolhapur Steel Limited in 2007 and Hematic Motors in 2010.

KBL has eight manufacturing facilities in India at Kirloskarvadi, Dewas, Kondhapuri, Shirwal, Sanand, Kaniyur, Kolhapur and Karad. In addition, KBL has global manufacturing and packaging facilities in Egypt, South Africa, Thailand, The Netherlands, United Arab Emirates, United Kingdom and United States of America. KBL has 12,700 channel partners in India and 80 overseas and is supported by best-in-class network of Authorised Centres and Authorised Refurbishment Centres across the country.

All the manufacturing facilities at KBL are certified for ISO 9001, ISO 14001, ISO 50001, BS OHSAS 18001 and SA8000. In addition, the Kirloskarvadi plant is also certified for N & NPT Stamp. KBL's corporate office in Pune is certified for ISO 9001 & Sa8000.

The factories deploy Total Quality Management tools using European Foundation for Quality Management (EFQM) model. The Kirloskarvadi plant of KBL is a state-of-the-art integrated manufacturing facility having Asia's largest hydraulic research centre with testing facility upto 5000 kW and 50,000 m<sup>3</sup>/hr.

KBL is the ninth pump manufacturing company in the world to be accredited with the N and NPT certification by American Society of Mechanical Engineers (ASME).

---

Pumps | Valves | Hydro Turbines | Turnkey Projects

Water Resource Management | Irrigation | Power | Industry | Oil & Gas | Marine & Defence | Building & Construction | |  
Distribution (Small Pumps) | Valves | Customer Service & Spares

---

## KIRLOSKAR BROTHERS LIMITED

Established 1888

A Kirloskar Group Company

### Global Headquarters & Registered Office

"Yamuna", S.No.98(3-7), Plot No. 3, Baner, Pune - 411045, Maharashtra, India.  
Phone: +91 (20) 27214444 | Email:marketing@kbl.co.in | Fax No. 020 67211060  
Website : www.kirloskarpumps.com | CIN No. L29113PN1920PLC000670.



#### OUR COMPANIES



United Kingdom



U.S.A.



South Africa



India



The Netherlands