



Enriching Lives

HORIZONTAL AXIALLY SPLIT-CASING PUMPS

TYPE- SCT



KIRLOSKAR BROTHERS LIMITED

A Kirloskar Group Company



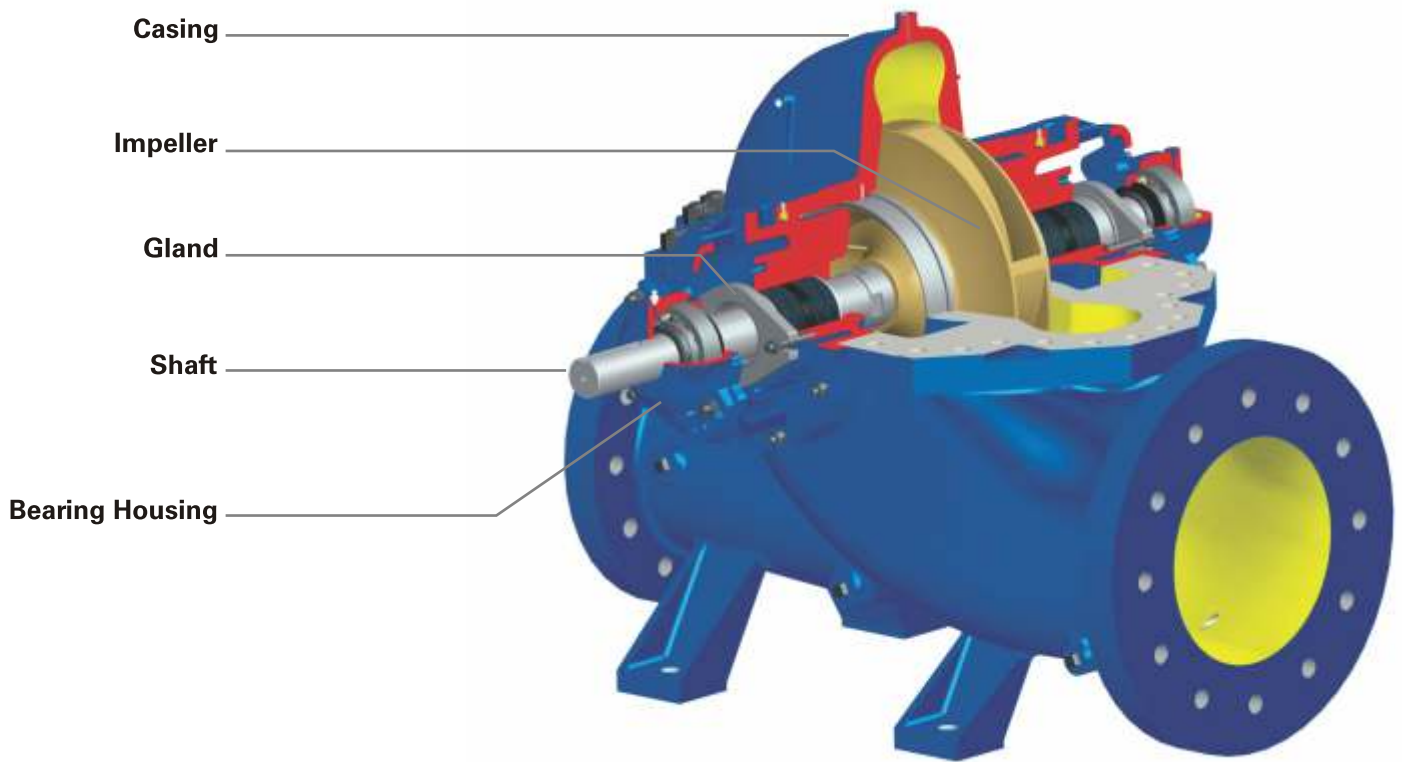

RANGE

Delivery size up to 250 mm

Capacity up to 1100 m³/hr

Head up to 115 metres

APPLICATIONS

Suitable for handling water with slight impurities in Industries, Water Works, Irrigation, Sprinkler Irrigation, Fire-fighting, Air Conditioning Plants, Water Circulation, Processing Plants.

CONSTRUCTIONAL FEATURES

These are horizontal axially split casing, single stage, double suction or single suction pumps with horizontal shaft and detachable stuffing box called Insert. Variety of models are available to operate to 50Hz.

- Direct or gear drive
- Suitable for higher working pressures
- Rotating assembly available for inspection or maintenance by removing only upper half casing without disturbing suction and delivery piping and motor
- Pump axis horizontal or vertical
- Vertical pump, direct drive or with universal shaft arrangement
- Highest hydraulic and overall efficiency due to latest design and manufacturing techniques
- Very high efficiency in the operating range
- Good suction performance and low NPSH
- Stable characteristics
- Minimum maintenance required
- Vibration free performance
- Highest reliability
- High degree of interchangeability of components

Pump Casing :

Horizontal axially split volute type, suction and discharge nozzles and supporting feet are cast integral with lower half casing.

Impeller :

Double or single suction type accurately balanced. In the case of double suction impellers, the hydraulic thrust is balanced automatically because of pressure equalization on both sides of the impeller.

Shafts :

The high tensile steel shaft accurately machined and ground is supported by antifriction bearings. The shaft is protected by shaft sleeves from wear in stuffing box area.

Stuffing Box :

Can be sealed by gland packing or by mechanical seal and is suitable for liquids having temperature from (-) 8°C to 90°C. In special cases packing or mechanical seal can be offered upto 120°C.

Bearings :

Deep groove ball bearings are provided. Standard lubrication is grease.

Direction Of Rotation :

Standard : Clockwise viewed from driving end.

Optional : Anticlockwise viewed from driving end.

Drive :

Suitable for coupling with electric motors, I.C. engines or steam turbines either directly or through belt drives.

Flanges :

Standard : Drilled to BS : 4504 PN 16 F. F.

Optional : DIN 2533, ND16, BS 4504, PN 25 ASA 125/150

GENERAL DIMENSIONS / MOUNTING DETAILS

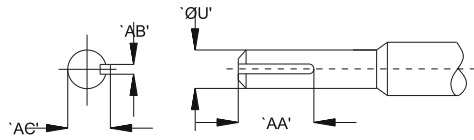
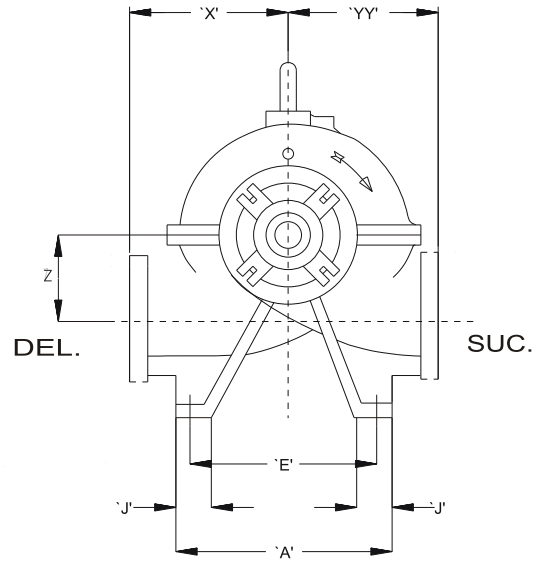
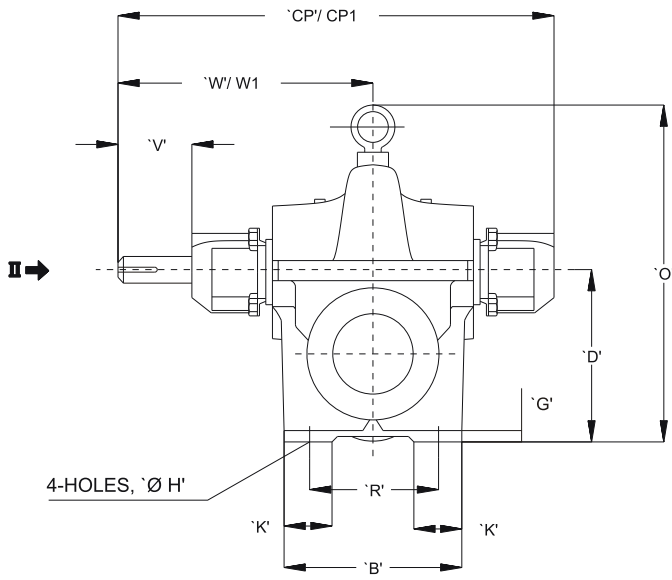

MODUL NO.	Ø'U'	'AA'	'AB'	'AC'
1	25 _{j6}	63.5	8	28
2	42 _{k6}	89.0	12	45
3	55 _{m6}	102.0	16	59

DIMENSIONS

Pump Type	SUC	DEL	Module No.	A	B	D	E	G	H	J	K	O	R	U	V	W	X	Z	CP	YY	Wt. Kg.
50/38*	80	50	1	400	330	300	340	25	22	65	65	642	270	25	71	398.5	280	170	730	355	196
65/24	80	65	1	350	300	250	290	25	22	65	65	492	240	25	71	398.5	225	130	730	280	130
80/24	100	80	1	350	300	280	290	25	22	65	65	582	240	25	70	398.5	230	130	730	270	142
80/30	100	80	1	350	300	280	290	25	22	65	65	554	240	25	71	398.5	275	150	730	290	159
80/38*	100	80	1	400	330	320	340	25	22	65	65	645	270	25	70	398.5	350	175	730	340	196
100/30	125	100	1	350	300	320	290	25	22	65	65	620	240	25	71	398.5	275	170	730	320	189
125/24	150	125	1	400	330	340	340	25	22	75	75	635	270	25	71	430	250	180	792	350	254
125/29	150	125	1	350	300	340	290	25	22	75	75	632	240	25	71	398.5	290	160	730	210	196
125/30	150	125	1	400	330	340	340	25	22	75	75	648	270	25	71	430	290	175	792	335	249
150/24	200	150	1	400	330	390	340	25	22	75	75	694	270	25	71	430	310	200	792	365	290
100/24	150	100	2	350	350	340	290	25	22	75	75	648	240	42	102	500	250	170	902	310	210
100/38	125	100	2	450	330	340	390	25	22	75	75	686	270	42	102	500	350	190	902	340	280
125/38	150	125	2	450	330	390	390	25	22	75	75	770	270	42	102	500	350	210	902	400	354
150/30	200	150	2	400	420	440	340	25	22	75	75	800	360	42	102	500	315	235	902	365	336
150/38	200	150	2	400	420	440	340	25	22	75	75	815	360	42	102	500	350	210	902	410	377
200/30	250	200	2	510	500	540	450	25	22	75	75	922	440	42	102	545	385	285	990	450	511
250/24	250	250	2	400	420	440	340	25	22	75	75	813	360	55	127	545	340	210	990	490	460
250/30	250	250	2	510	500	540	450	25	22	75	75	930	440	55	127	545	400	250	990	430	492
150/48	100	150	3	560	460	540	490	28	27	90	90	990	390	55	127	585	450	270	1046	510	647
200/38	250	200	3	510	420	460	440	28	27	90	90	870	350	55	127	585	420	225	1046	480	574
200/48	250	200	3	560	500	540	490	28	27	90	90	985	430	55	127	585	450	270	1046	550	618
200/48C	250	200	3	560	500	540	490	28	27	90	90	985	460	55	127	585	450	270	1046	550	618
250/38	300	250	3	560	500	540	490	28	27	90	90	1010	430	55	127	585	420	265	1046	590	747

NOTES:

- All dimensions are in mm
- Flanges drilled to BS 4504 PN 16 flat faced
- * These pumps are single suction pumps
- All above dimensions are for soft packed pumps.

CROSS SECTIONAL VIEW SCT PUMP (DOUBLE SUCTION)

CROSS SECTIONAL ASSEMBLY OF SCT PUMPS (MODULE 1 & 2)
SOFT PACKED ARRANGEMENT.

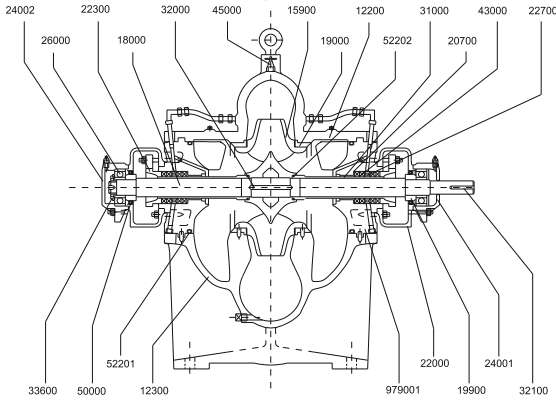

CROSS SECTIONAL ASSEMBLY OF SCT PUMPS (MODULE 3)
SOFT PACKED ARRANGEMENT.

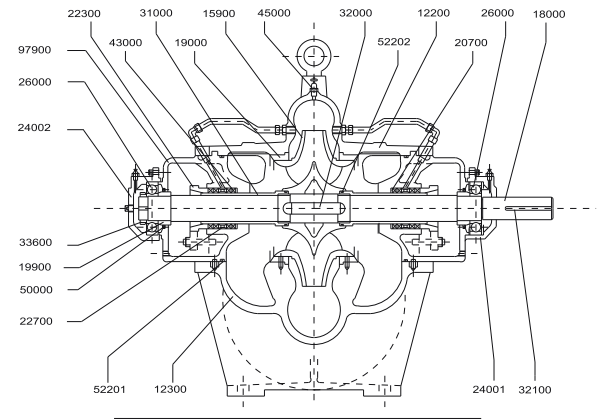

SCT Pump (Single Suction)

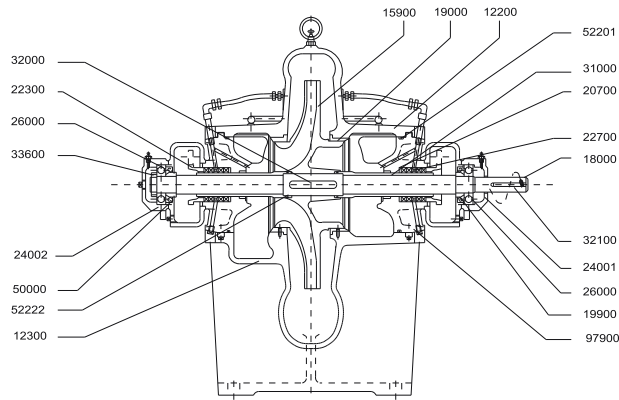

INTERCHANGEABILITY OF COMPONENTS

PART NO.	NAME OF THE PART	TOTAL NO. OF PARTS	PUMP TYPE																							
			65/24	80/24	125/24	150/24	125/29	80/30	100/30	125/30	50/38	80/38	100/24	250/24	150/30	200/30	250/30	100/38	125/38	150/38	200/38	250/38	150/48	200/48	200/48C	
			MODULE - 1												MODULE - 2						MODULE - 3					
INTERCHANGEABILITY IDENTITY NUMBER																										
12200	Upper Half Casing	22	1	2	3	4	5	6	7	8	9	10	11	12	13	14	15	16	17	18	19	20	21	22	22	
12300	Lower Half Casing	22	1	2	3	4	5	6	7	8	9	10	11	12	13	14	15	16	17	18	19	20	21	22	22	
15900	Impeller	22	1	2	3	4	5	6	7	8	9	10	11	12	13	14	15	16	17	18	19	20	21	22	22	
18000	Pump Shaft	5	1	1	2	2	1	1	1	2	1	1	3	4	3	4	4	3	3	3	5	5	5	5	5	
19000	Wear Ring	9	1	1	5	5	5	1	2	5	3	3	4	7	6	7	7	4	6	6	8	8	9	8	8	
19900	Shoulder Ring	3	1	1	1	1	1	1	1	1	1	1	2	2	2	2	2	2	2	2	3	3	3	3	3	
20700	Stuffing Box Packing Ring	3	1	1	1	1	1	1	1	1	1	1	2	2	2	2	2	2	2	2	3	3	3	3	3	
22300	Gland	3	1	1	1	1	1	1	1	1	1	1	2	2	2	2	2	2	2	2	3	3	3	3	3	
22700	Split Lantern Ring	3	1	1	1	1	1	1	1	1	1	1	2	2	2	2	2	2	2	2	3	3	3	3	3	
240.1	Bearing Housing De	3	1	1	1	1	1	1	1	1	1	1	2	2	2	2	2	2	2	2	3	3	3	3	3	
240.2	Bearing Housing Nde	3	1	1	1	1	1	1	1	1	1	1	2	2	2	2	2	2	2	2	3	3	3	3	3	
26000	Ball Bearing	3	1	1	1	1	1	1	1	1	1	1	2	2	2	2	2	2	2	2	3	3	3	3	3	
31000	Shaft Sleeve	3	1	1	1	1	1	1	1	1	1	1	2	2	2	2	2	2	2	2	3	3	3	3	3	
32100	Coupling Key	3	1	1	1	1	1	1	1	1	1	1	2	2	2	2	2	2	2	2	3	3	3	3	3	
33600	Bearing Lock Nu	3	1	1	1	1	1	1	1	1	1	1	2	2	2	2	2	2	2	2	3	3	3	3	3	
50000	Oil Seal	3	1	1	1	1	1	1	1	1	1	1	2	2	2	2	2	2	2	2	3	3	3	3	3	
522.1	"o" Ring Insert	5	1	1	3	3	2	1	2	3	2	2	2	4	3	4	4	4	3	3	5	5	5	5	5	
522.2	"o" Ring Shaft Sleeve	3	1	1	1	1	1	1	1	1	1	1	2	2	2	2	2	2	2	2	3	3	3	3	3	
97900	Insert Soft Packed	7	1	1	3	3	2	1	2	3	2	2	4	6	5	6	6	6	5	5	7	7	7	7	7	
22000	Stuffing Box Cover For Module (i & li)only	2	1	1	1	1	1	1	1	1	1	1	2	2	2	2	2	2	2	-	-	-	-	-		

ALTERNATIVES AVAILABLE PUMP WITH MECHANICAL SEAL ARRANGEMENT

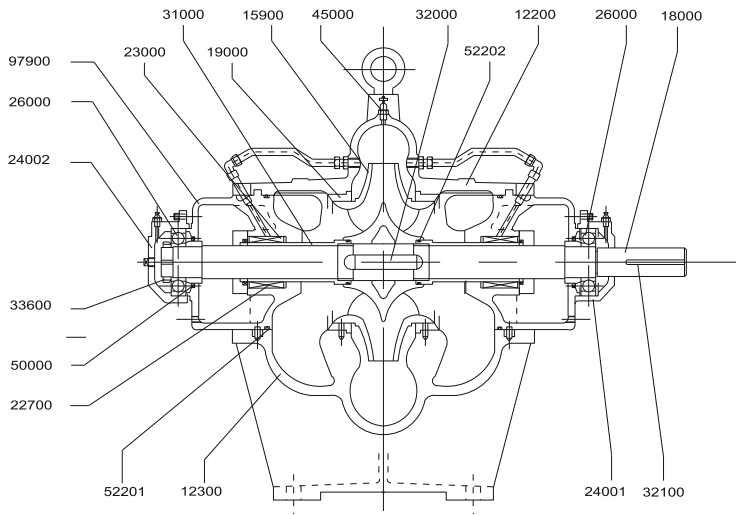

MECHANICAL SEAL ARRANGEMENT

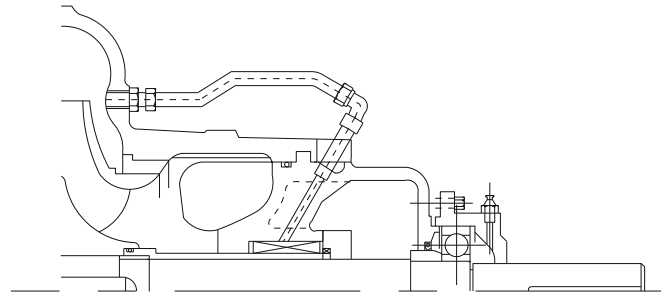

FAMILY CURVES

SCT Pumps at 1450 rpm - 50 Hz

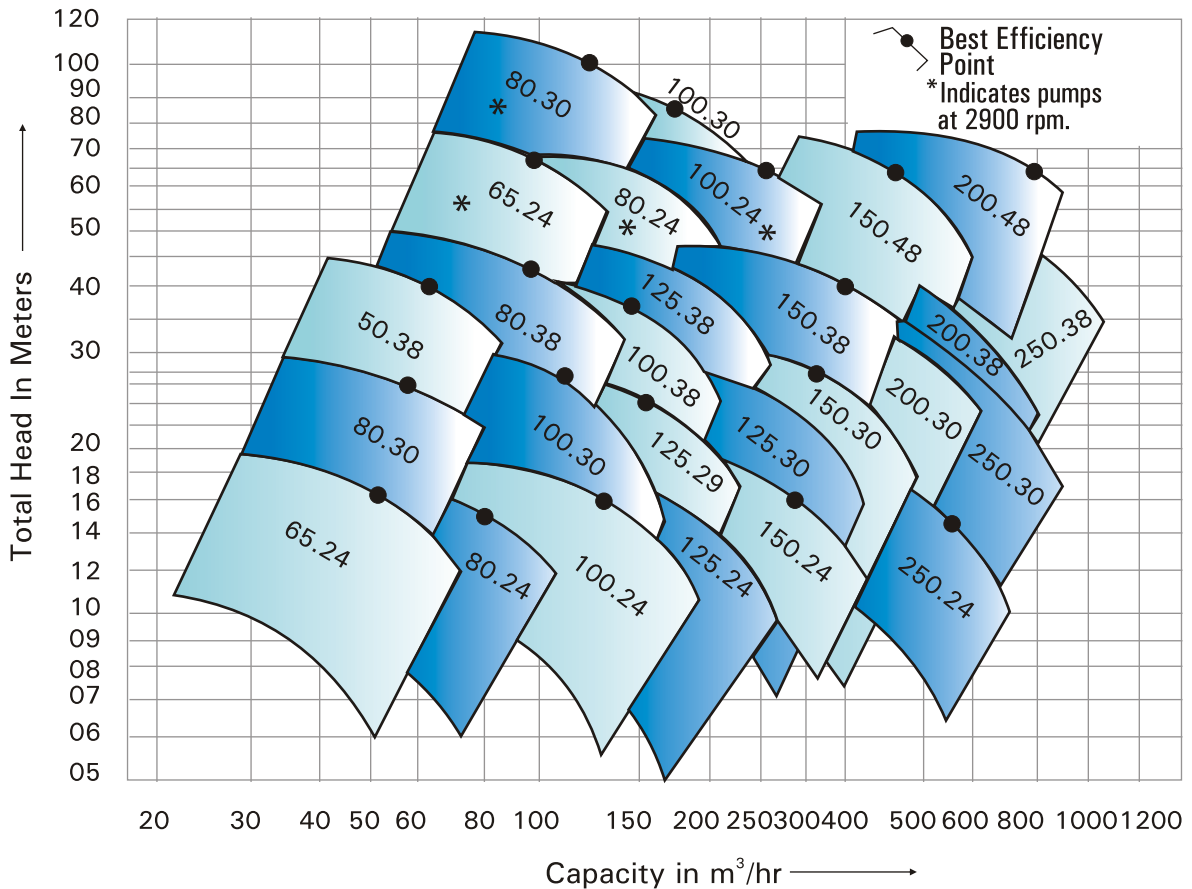

MATERIALS

MATERIAL OF CONSTRUCTION

Casing Half Upper / Lower	Cast Iron / Cast Steel / Stainless Steel / Duplex Steel
Impeller	Cast Iron / Bronze / Phosphor Bronze / Cast Steel / Stainless Steel / Chrome Steel / Duplex Steel
Wear Ring	Cast Iron / Bronze / Steel
Shaft	Carbon Steel / Stainless Steel / Duplex Steel
Shaft Sleeve	Stainless Steel / Bronze

MATERIAL STANDARDS - GENERAL INFORMATION

Material Type	Indian Standard (IS)	American standard (ASTM)	DIN
Cast Iron			
Cast Iron	IS 210 Gr. FG 260	ASTM A48 Class 40	(0.6025)DIN 1691 GG25
Spheroidal Graphite Cast Iron			
SG Iron (Ductile Iron)	IS 1865 Gr 400/15	A536, 60-40-18	(0.7040)DIN1693 GGG40
SG Iron (Ductile Iron)	IS 1865 Gr 500/7	A536, 65-45-12	(0.7050)DIN1693 GGG50
Carbon steel			
Carbon steel (Wrought)	IS 1570 (part II) Gr. 40C8	ASTM A107 Gr. 1040	(1.1186)C40E/CK40
Carbon steel (Wrought)	IS 1570 (part II) Gr. 20C8	ASTM A107 Gr. 1020	(1.0402)C22
MS Steel	MS IS 2062 - Fe 410 W A	ASTM-A283 GR.D	DIN 1700 GR ST4-2 FABRICATED STEEL44
Cast Steel Grades			
Cast steel		ASTMA 216 Gr. WCB	1.0619(GS-C25)
Cast Stainless Steel			
Stainless Steel CF8M	IS 3444 Gr. 4	ASTMA 351 Gr. CF8M	1.4408(GX5CrNiMo19-11-2)
Stainless Steel CF8M	IS 3444 Gr. 4	ASTMA 743 Gr. CF8M	1.4408(GX5CrNiMo19-11-2)
Stainless Steel CF3M	IS 3444 Gr. 16	ASTMA 351 Gr. CF3M	1.4409(GX2CrNiMo19-11-2)
Stainless Steel CF3M	IS 3444 Gr. 16	ASTMA 743 Gr. CF3M	1.4409(GX2CrNiMo19-11-2)
Stainless Steel CF8	IS 3444 Gr. 1	ASTMA 351 Gr. CF8	1.4301(X5CrNi18-10)
Stainless Steel CF3	IS 3444 Gr. 15	ASTMA 351 Gr. CF3	1.4306(X2CrNi19 11)
Cast Chromium StainlessSteel			
Stainless Steel CA15	IS 3444 Gr. 10	ASTMA 217 Gr. CA15	1.4106&1.448(DIN17445 GX12Cr14)
Stainless Steel CA15	IS 3444 Gr. 10	ASTMA 743 Gr. CA15	1.4106&1.448(DIN17445 GX12Cr14)
Stainless Steel CA6NM	IS 3444 Gr. 24	ASTMA 487 Gr. CA6NM	1.4313&1.4317(GX5CrNiMo13-4)
Stainless Steel CA6NM	IS 3444 Gr. 24	ASTMA 743 Gr. CA6NM	1.4313&1.4317(GX5CrNiMo13-4)
Chromium StainlessSteel Round Bar Material			
Stainless steel 410	IS 1570 (part V) Gr. X12Cr12	ASTMA 276 type 410	1.4006(X10Cr13)
Stainless steel 420	IS 1570 (part V) Gr. X20Cr13	ASTMA 276 type 420	1.4021(X20Cr13)
Stainless steel 431	IS 1570 (part V) Gr. X15Cr16Ni2	ASTMA 276 type 431	1.4057(X20CrNi17)
Stainless steel 316	IS 1570 (part V) Gr. X04Cr17Ni12Mo2	ASTMA 276 type 316	1.4401(X5CrNiMo17122)
Stainless steel 316L	IS 1570 (part V) Gr. X02Cr17Ni12Mo2	ASTMA 276 type316L	1.4404(X2CrNiMo1810)
Cast Duplex Steel			
Duplex Steel 1A		ASTMA 890 Gr. CD4MCu	25Cr-5Ni-Mo-Cu
Duplex Steel 2A		ASTMA 890 Gr. CE8MN	24Cr-10Ni-Mo-N
Duplex Steel 3A		ASTMA 890 Gr. CD6MN	25Cr-5Ni-Mo-N
Super Duplex steel 4A		ASTMA 890 Gr. CD3MN	25Cr-7Ni-Mo-N
Super Duplex steel 5A		ASTMA 890 Gr. CE3MN	24Cr-10Ni-Mo-N
Non Ferious Materials			
Bronze	IS 318 Gr. LTB2 (CuSn5Zn5Pb5C)	ASTMB 584 - C90500	DIN 1705 Rg 5
Phosphor Bronze	IS 28 Gr. 1 (CuSn11PC)		
Zinc Free Bornze	IS 28 Gr. 1 (CuSn10C)		

ABOUT KBL

Kirloskar Brothers Limited (KBL) is a world class pump manufacturing company with expertise in engineering and manufacture of systems for fluid management. Established in 1888 and incorporated in 1920, KBL is the flagship company of the \$ 2.1 billion Kirloskar Group. KBL, a market leader, provides complete fluid management solutions for large infrastructure projects in the areas of water supply, power plants, irrigation, oil & gas and marine & defence. We engineer and manufacture industrial, agriculture and domestic pumps, valves and hydro turbines.

In 2003, KBL acquired SPP Pumps, United Kingdom and established SPP INC, Atlanta, USA, as a wholly owned subsidiary of SPP, UK to expand its international presence. In 2007, Kirloskar Brothers International B.V., The Netherlands and Kirloskar Brothers (Thailand) Ltd., a wholly owned subsidiary in Thailand, were incorporated. In 2008, KBL incorporated Kirloskar Brothers Europe B.V. (Kirloskar Pompen B.V. since June 2014), a joint venture between Kirloskar International B.V. and Industrial Pump Group, The Netherlands. In 2010, KBL further consolidated its global position by acquiring Braybar Pumps, South Africa. SPP MENA was established in Egypt in 2012. In 2014, KBL acquired SyncroFlo Inc., the largest independent fabricator of commercial and municipal domestic water booster pumps.

To further strengthen its global position, in 2015, Kirloskar Pompen B.V. acquired Rodelta Pumps International, The Netherlands.

KBL has joint venture cooperation with Ebara, Japan since 1988 for the manufacture of API 610 standard pumps. Kirloskar Corrocoat Private Limited is a joint venture cooperation with Corrocoat, UK since 2006. KBL acquired The Kolhapur Steel Limited in 2007 and Hematic Motors in 2010.

KBL has eight manufacturing facilities in India at Kirloskarvadi, Dewas, Kondhapuri, Shirwal, Sanand, Kaniyur, Kolhapur and Karad. In addition, KBL has global manufacturing and packaging facilities in Egypt, South Africa, Thailand, The Netherlands, United Arab Emirates, United Kingdom and United States of America. KBL has 12,700 channel partners in India and 80 overseas and is supported by best-in-class network of Authorised Centres and Authorised Refurbishment Centres across the country.

All the manufacturing facilities at KBL are certified for ISO 9001, ISO 14001, ISO 50001, BS OHSAS 18001 and SA8000. In addition, the Kirloskarvadi plant is also certified for N & NPT Stamp. KBL's corporate office in Pune is certified for ISO 9001 & Sa8000.

The factories deploy Total Quality Management tools using European Foundation for Quality Management (EFQM) model.

The Kirloskarvadi plant of KBL is a state-of-the-art integrated manufacturing facility having Asia's largest hydraulic research centre with testing facility upto 5000 kW and 50,000 m³/hr.

KBL is the ninth pump manufacturing company in the world to be accredited with the N and NPT certification by American Society of Mechanical Engineers (ASME).

Pumps | Valves | Hydro Turbines | Turnkey Projects

Water Resource Management | Irrigation | Power | Industry | Oil & Gas | Marine & Defence | Building & Construction | |
Distribution (Small Pumps) | Valves | Customer Service & Spares

KIRLOSKAR BROTHERS LIMITED

A Kirloskar Group Company

Registered Office: Udyog Bhavan, Tilak Road , Pune 411002. Tel: +91(20)24440770
Global Headquarters: "Yamuna", Survey No. 98/(3.7), Baner, Pune 411045. Tel: +91(20)27214444
Email: marketing@kbl.co.in, Website: www.kirloskarpumps.com, CIN No.: L29113PN1920PLC000670

OUR COMPANIES

